



## E17UAC-20

### Aluminum Full Size Non-Insulated Heater / Proofer



**SIZE:**

**E17UAC-20**

66-1/2" High, 27-5/8" Wide, 31-5/8" Deep  
1689 mm High, 702 mm Wide, 804mm Deep

**Toastmaster's E17UAC-20** - In locations where cabinets will be used primarily for holding with infrequent serving applications (gauged by door openings) or in situations with limited start-up budgets, the non-insulated cabinet would satisfy most requirements. In higher volume operations with more frequent serving applications the insulated cabinet would be the better choice as it delivers a faster recovery and greater consistency of temperature.

**CONSTRUCTION:**

- Aluminum construction
- Removable heating console
- Removable universal pan slides

**CONTROLS:**

- Mechanical controls
- Maximum Temperature 175°F

**STANDARD FEATURES:**

- Air baffle and circulation air blower provide even heat distribution
- Aluminum construction
- Set of 5" swivel casters with brakes
- Lexan door
- Magnetic door gaskets
- Lift-off door

**OPTIONAL FEATURES:**

- Push handle
- Transport latch
- Solid door (order as E17UAC-SD-20)
- 6" indoor/outdoor casters (set of 4)
- Also available in 15 amps.  
Model # E17UAC-INS-15  
12.5 amps - NEMA 5-15P

Toastmaster E17UAC-20 Aluminum Full Size Non-Insulated Heater / Proofer

# E17UAC-20

## Aluminum Full Size Non-Insulated Heater / Proofer

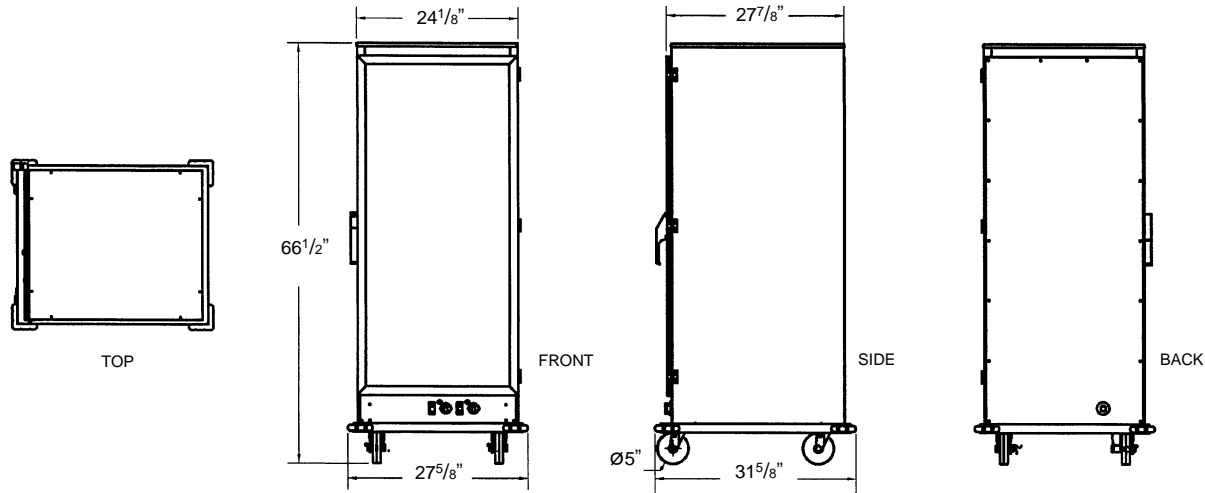

**SPECIFICATIONS:**

**SERVICE CONNECTIONS:**

- Unit provided with 6 foot detachable cord and plug.
- Removable console consisting of blower, three-way toggle switch, running lights to indicate heater (holding) or proofing mode, stainless steel water reservoir.
- Element controlled by 180 degrees thermostat.  
1500 Watts in heating mode.  
1500 Watts in proofing mode.

**CAPACITY:**

Heater/Proofer	18"x26" Full Size Sheet Pans	12"x20"x2-1/2" Food Service Pans
	17	34
Spacing	3"	3"

**DIMENSIONS:**

	Height	Width	Depth
Exterior	66-1/2"	27-5/8"	31-5/8"

**ELECTRICAL:**

Amp Draw	120/1	208/3	240/1	240/3
L1	14	n/a	n/a	n/a

- Also available in 15 amps.  
Model # E17UAC-INS-15  
12.5 amps - NEMA 5-15P

**DOOR SWING:**

- Door swings 270 degrees to the recessed side of the cabinet

**PACKING SIZE:**

74" High, 28" Wide, 40" Deep  
(1880 mm High, 711 mm Wide, 1016 mm Deep)

**SHIPPING WEIGHT:**

140 Pounds, FOB Menominee, MI 49858

**INSTALLATION:**

Allow four inches on each side and back of unit for ventilation of heater/proofer.

**INTENDED FOR COMMERCIAL USE ONLY. NOT FOR HOUSEHOLD USE.**



Toastmaster, in line with its policy to continually improve its product, reserves the right to change materials or specifications without notice. Such revisions do not entitle the buyer to corresponding changes, improvements, additions, or replacements for previously purchased equipment.

